

REAR FLANGE

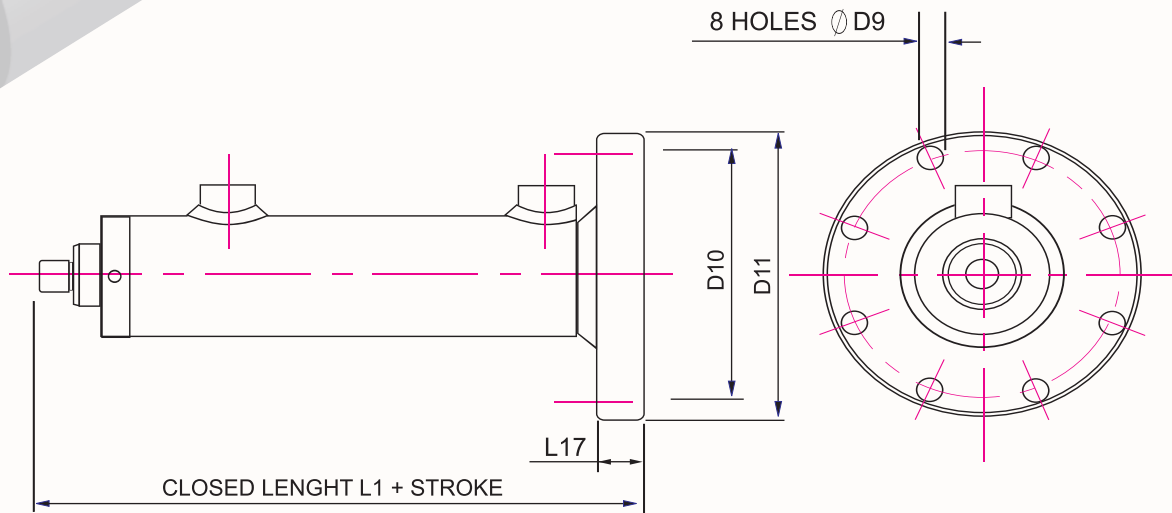

Cylinder size	D9	D10	D11	L1	L17
40 X 20	11	120	140	134	18
50 X 25	11	126	145	141	18
2" X 1 1/4"	3/8"	5"	5 3/4"	5 1/2"	3/4"
50 X 32	11	126	145	141	18
63 X 32	14	145	170	160	20
2 1/2" X 1 1/2"	1/2"	5 3/4"	6 3/4"	6 1/4"	3/4"
63 X 40	14	145	170	160	20
80 X 40	18	165	200	180	24
3 1/4" X 2"	3/4"	6 1/2"	7 7/8"	7"	1"
80 X 50	18	165	200	180	24
3 1/4" X 2 1/4"	3/4"	6 1/2"	7 7/8"	7"	1"
80 X 60	18	165	200	180	24
4" X 2"	7/8"	7 7/8"	9 1/2"	8"	1/8"
100 X 50	22	200	240	201	28
4" X 2 1/2"	7/8"	7 7/8"	9 1/2"	8"	1/8"
100 X 63	22	200	240	201	28
100 X 70	22	200	240	201	28
5" X 2 1/2"	7/8"	9 1/4"	10 5/8"	9 1/8"	1 3/8"
125 X 63	22	235	270	233	34
5" X 3"	7/8"	9 1/4"	10 5/8"	9 1/8"	1 3/8"
125 X 80	22	235	270	233	34
5" X 3 1/2"	7/8"	9 1/4"	10 5/8"	9 1/8"	1 3/8"
125 X 90	22	235	270	233	34
6" X 3 1/4"	7/8"	11"	12 5/8"	11 1/4"	1 1/2"
160 X 80	22	280	320	287	38
6" X 4"	7/8"	11"	12 5/8"	11 1/4"	1 1/2"
160 X 100	22	280	320	287	38

Phone:

+27 11 828 5506
+27 11 828 5508

Fax:

+27 11 828 1162

Web:

www.kappaeng.co.za

e-mail:

sales@kappaeng.co.za